



## ET75

### Tracked conventional excavator

durable and powerful

Constructed of high-grade steel and other quality, heavy-duty components for extreme durability. Other impressive features of the ET75 include high stability, increased lift capacity and an optional dozer blade. The large diesel tank allows for longer working times between refueling and ensures better performance.

## Highlights

- Powerful drive system with LUDV
- Optimal maintenance access
- High degree of digging power
- AUX I
- Optimized hydraulics or engine-pump management

## Technical Data

### Hydraulic

operating pressure	285,0 bar
flow rate	144,0 l/min
tank capacity	96,0 l

### Mechanical - Output Details

Nominal Engine speed	2.000,0 1/min
travel speed stage 1	2,5 km/h
travel speed stage 2	4,8 km/h

### Mechanical Details

Length	6.270,0 mm
Width	2.252,0 mm
Height	2.559,0 mm
Aggr. pwr time limited 1~(LTP)	6.800,0 - 7.320,0 kg
Digging depth (max.)	4.097,0 mm

### Engine

Cooling	water-cooling
Engine type	Diesel engine
Cylinder capacity	3.054,0 cm <sup>3</sup>
tank capacity	145,0 l
Effective power	35,9 KW
Nominal Engine speed	2.000,0 1/min

Operating power	35,9 KW
Operating Engine speed	2.000,0 1/min
Starter battery Voltage	12,0 V
Battery capacity (nom. value)	120,0 Ah
Manufacturer	Yanmar
Engine designation	4TNV94L-ZWWN

### Environment Data

Sound power LWA, measured	99,0 dB(A)
Sound power LWA, guaranteed	99,0 dB(A)

### Operating Fluids

Oil volume	11,600 l
Cooling fluid volume	10,0 l
Hydraulic fluid volume	105,0 l

### Chassis

drive unit	axialpistonmotor with RGU
operating pressure	285,0 bar

### Shipping and Storage

Length for shipping	6.270,0 mm
Width for shipping	2.252,0 mm
Height for shipping	2.559,0 mm
Shipping weight	6.615,0 kg

## Dimensions

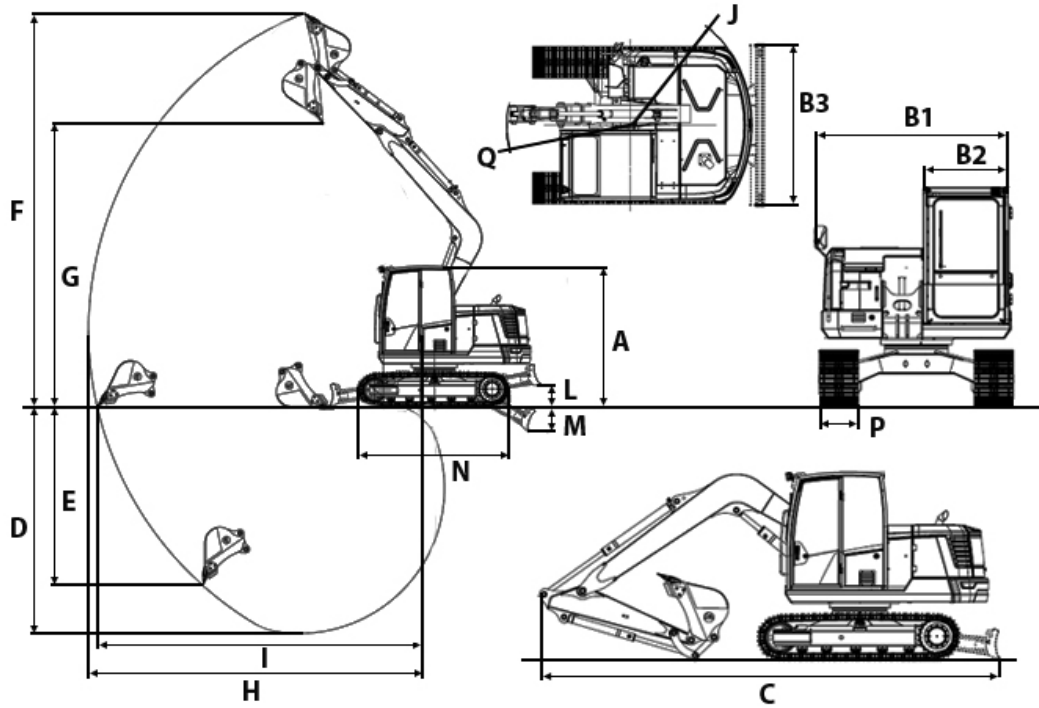

A	Height with cab	2,559 mm
B1	Width of upper carriage	2,252 mm
B2	Width of cab	988 mm
B3	Width of dozer blade	2,320 mm
C	Transport length	6,270 mm
D	Digging depth max.	4,097 mm
E	Piercing depth max.	3,219 mm
F	Piercing height max.	7,139 mm
G	Dumping height max.	5,153 mm
H	Digging radius max.	6,264 mm
I	Max. reach at ground level	6,106 mm
J	Tail swing radius	1,777 mm
L	Stacking height max. (dozer blade above surface)	390 mm
M	Digging depth max. (dozer blade below surface)	452 mm
N	Length travel drive	2,755 mm
P	Track width	450 mm
Q	Boom swing radius center	1,753 mm